

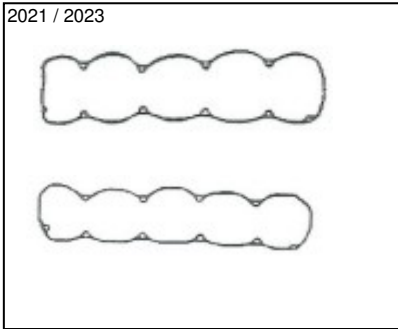

8140.21

4 cil. 93.00 mm 2.445 c.c.

35.10 - 35.10 Restyling - 40.10 - A40.10 Bus - 45.10 - A45.10 Bus
45.10 Restyling - 49.10 - 49.10 - Restyling
Turbo

Componente	oe	Ref.	I.	U.	Observaciones	Ref. Origen
10 Cigüeñal		10780		1	carrera 90 volante 90 /	1907548
		19680		1	carrera 92 - volante 100 / Casquillo 32 mm	99437215
11 Biela		40420		4	recta /	7473171
		44730		4	cónica /	500352497
12 Tornillo biela		390360		8		98460577
14 Cojinete biela	oe	160480		4	56.52 Ø / ancho 24.70 mm /	1901926
15 Cojinete bancada		840370		1	76.18 Ø / ancho 25.00 / 31.95 mm /	7300279
20 Culata	oe	102151		1	Centrador 10 mm / Colector redondo	7303032
		105860		1	Centrador 13 mm / Iny. Dir.	2991607
21 Arbol de Levas		20540		1	Hasta motor 135 93 74 /	7301255
24 Tornillo Culata		480160	☒	10	Largo 119 mm	4854648
		480130	☒	12	Largo 162 mm	4828150
25 Taquet		220210		8		4733350
40 41 43 Juntas		2021		1	Juntas Descarbonizar sin culata	
		2023		1	Juntas Descarbonizar sin culata	
		5000		1	Juntas Suplementario con retenes / 90 mm	
		5002		1	Juntas Suplementario con retenes 100 mm	
		1021		1	Junta de culata / Centrador 10 mm /	
		1035		1	Junta de Culata / 1.20 mm / Centrador 13 mm /	
		1036		1	Junta de Culata / 1.30 mm / Centrador 13 mm /	
		1037		1	Junta de Culata / 1.40 mm / Centrador 13 mm /	
	1038		1	Junta de Culata/ 1.50 mm / Centrador 13 mm /		
		2021 / 2023				
		5000 / 5002				
		1035 / 1036 / 1037 / 1038				

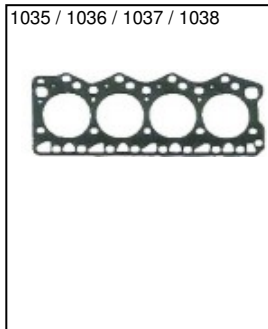
8140.21 (Cont.)

Componente	oe	Ref.	I.	U.	Observaciones	Ref. Origen
55		Bomba Aceite	140131	1		504027985
56	oe	Turbo	660370	1	KKK /	7302470
57		Volante Motor	180600	1		4755854
58		Corona Volante	310510	1		4279804
60		Kit Motor	620180	1		1907475
70		Bloque Motor	32820	1	Volante 90 mm / Volante 100 mm	1903661
71		Motor Aligerado	81620	1		8092252
72		Motor Semi	91340	1		4836396